

Steel Drum Regulated and Non Regulated Container Closure & Assembly Instructions

UN certified container closures must be installed and secured in accordance with the following procedure and specifications

This Procedure is for new steel drums manufactured by GENERAL STEEL DRUM, LLC only!

To ensure compliance to UN markings, the filler/shipper must inspect and confirm all closures are properly installed and at proper torque prior to shipping.

DO NOT MIX DIFFERENT DRUM MANUFACTURERS' COMPONENTS! For drums manufactured / re-manufactured by others suppliers, consult your specific supplier closing requirements.

OPENHEAD DRUM CLOSURE PROCEDURE

1. Inspect gasket for proper seating and remove any residue from curl prior to cover installation.
2. Place cover on drum, making sure the cover gasket is seated against drum curl and gasket is securely recessed in cover channel. The gasket may not protrude outside the cover or drum curl or be sagging inside drum. If drum has a poly liner, the curl area must be free of wrinkles.
3. Place cover ring onto drum. Make sure bolt ring is oriented so lugs are positioned below top surface of drum. Ensure it is centered on drum curl. Verify cover and drum curl are pinched together and within the recess of ring profile. You are required to pound ring with non-sparking mallet or use head press to compress gasket.
4. **For bolt ring**-insert bolt into ring right lug. Thread jam nut onto bolt, if needed, and then into threaded lug, and tighten bolt to specification. Hammer around circumference of ring while torque is applied to further seat head onto drum. Continue hammering on ring circumference and torque the bolt until the torque does not loosen when further hammering on the ring circumference is performed. Tighten jam nut against unthreaded lug. Ring ends must not touch when proper torque is applied.

For lever ring-hammer around circumference until lever can lock in place.

It is the filler's responsibility to verify the container has been properly closed prior to shipping filled drums



BUNG CLOSING PROCEDURES- Do not over tighten!

1. Inspect all bungs to ensure gaskets are in place and not twisted or damaged
2. Insert all bungs and hand thread in a clockwise direction until hand tight. Do not cross thread
3. Utilizing a CALIBRATED TORQUE WRENCH to torque and confirm all bungs are at required minimum torque.
4. Wipe clean any spillage or debris.
5. If required, apply applicable cap seals

Manufacturer's Recommendations [ft-lbs]-(tolerance +/- 10%)

Bung Type	○ Round Bung				○ Hexagon Bung			
	Steel		Poly / Nylon		Steel		Poly / Nylon	
Bung Material	Rubber	Poly	Rubber	Poly	Rubber	Poly	Rubber	Poly
Gasket Type	Rubber	Poly	Rubber	Poly	Rubber	Poly	Rubber	Poly
2"	20 ft-lb	30 ft-lb	20 ft-lb	20 ft-lb	30 ft-lb	40 ft-lb	20 ft-lb	20 ft-lb
1-1/2"	n/a	n/a	n/a	n/a	30 ft-lb	40 ft-lb	n/a	n/a
3/4"	9 ft-lb	15 ft-lb	9 ft-lb	9 ft-lb	15 ft-lb	20 ft-lb	9 ft-lb	9 ft-lb

For more information, call (800) 796-4226

www.generalsteeldrum.com

Notes:

- This document must be passed along with the container within your facility, or to whom the packaging is transferred, and ultimately to the personnel responsible for shipping and closure. It must be used as a training document to complete proper closure of your container.
- In order for your drum to safely perform to its rated ability, these assembly instructions must be strictly adhered to. Any other method of assembly will immediately invalidate the UN certification.
- Disassembly of a poly lined drum voids UN certification.

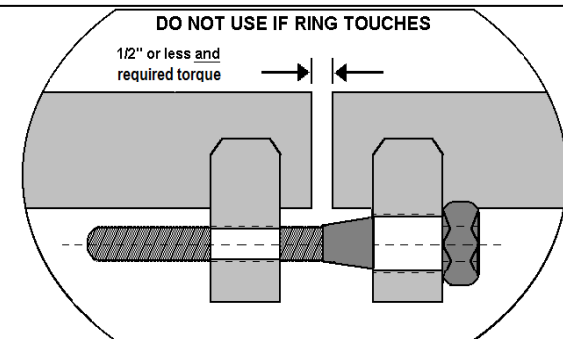

16 Gauge Ring: **Torque: 15 to 20 ft-lbs- No Jam Nut**

12 Gauge Forged Lug Ring: **Torque: 60 to 70 ft-lbs**
 5/8" Standard Drum Bolt...**Jam Nut Required**
 5/8" Shoulder Bolt... **No Jam Nut**